



SAILING INSTRUCTIONS

SNIPE CLASS INTERNATIONAL RACING ASSOCIATION

SOUTH AMERICAN CHAMPIONSHIP

23th to 31th March 2018

Clube dos Jangadeiros

Porto Alegre - Rio Grande do Sul - Brasil

1 RULES

- 1.1 The regatta will be governed by the rules as defined in *The Racing Rules of Sailing*.
- 1.2 No national authority prescriptions will apply.
- 1.3 The Rules of Conduct for Conducting National and International Championship and The trophy restrictions of South American Championship will apply. Any conflict arising between Deed of Gift and the SCIRA Rules of Conduct shall be solved by the application of Rules of Conduct.
- 1.4 In case of conflict between the Notice of Race and the Sailing Instruction the Sailing Instructions shall prevail.
- 1.5 If there is a conflict between languages the English text will take precedence.

2 NOTICES TO COMPETITORS

Notices to competitors will be posted on the official notice board(s) located at the event office.

3 CHANGES TO SAILING INSTRUCTIONS

- 3.1 Any change to the sailing instructions will be posted before 10:00 on the day it will take effect, except that any change to the schedule of races will be posted by 20:00 on the day before it will take effect.
- 3.2 Any change or amendment to the Sailing Instructions shall be approved with the SCIRA Representative.

4 SIGNALS MADE ASHORE

- 4.1 Signals made ashore will be displayed at location>.
- 4.2 When flag AP is displayed ashore, '1 minute' is replaced with 'not less than 60 minutes' in the race signal AP.
- 4.3 When flag Y is displayed ashore, rule 40 applies at all times while afloat. This changes the Part 4 preamble.

5 SCHEDULE OF RACES

- 5.1 Dates of racing:

Date	Time	Event
March, 23th Friday	9 am to 5 pm	Entries / Measurement
March, 24th Saturday	9 am to 11am 9 am to 5 pm	Entries Measurement
March, 25th Sunday	1:00 pm	Races master and mixed 1st warning signal
March, 26th Monday	1:00 pm	Races master and mixed 1st warning signal
March, 27th Tuesday	1:00 pm	Races master and mixed 1st warning signal
March, 28th Wednesday	2:00 pm	Races Open 1st warning signal
March, 29th Thursday	2:00 pm	Races Open 1st warning signal

March, 30th Friday	2:00 pm	Races Open 1st warning signal
March, 31th Saturday	1:00 pm 1:00 pm 7:00 pm	Races Open 1st warning signal Races Open 1st warning signal Prizes Giving - Closing Ceremony Prizes Giving - Closing Ceremony Closing Ceremony Crews departure
April, 1st Sunday		Crews departure

- 5.2 For the Mixed and Masters series, six (6) races are scheduled and two (2) races shall constitute a regatta.
- 5.3 For the Open series, ten (10) races are scheduled and three (3) races shall constitute a regatta
- 5.4 The maximum races sailed will be 3 (three) on a day.
- 5.5 To alert boats that a race or sequence of races will begin soon, an orange flag will be displayed with one sound for at least four minutes before a warning signal is made.
- 5.6 On the last day schedule of racing no warning signal will be made after 16:00
- 5.7 There may be a competitors meeting before the first race of each series, at 10:30 at the “Snipe Bar” and announced by two sound signals.

6 CLASS FLAGS

The official Class Flag shall be the Snipe Class flag:

- Master Category: Snipe insignia on a green background
- Mixed Category: Snipe insignia on a blue background
- Open Event: Snipe insignia on a white background

7 RACING AREAS

The Racing Area location is Pedra Redonda Bay.

8 WEATHER LIMITATION (Course and Starting)

8.1 For Open and Mixed series, the wind speed ranges shall be no less than 5 knots and not exceed 23 knots or in accordance with the applicable Deed of Gift.

For Masters series the maximum wind speed allowed shall 15 knots.

8.2 Wind reading instruments shall be between 2 and 3 meter above the surface of the water. The duration of reading shall be 3 consecutive minutes prior the race warning. The wind reading shall be taken from an unobstructed area on the boat, it is recommended that there be a minimum 4 meters of free space surrounding the wind instruments. If during the race the wind speed goes over the maximum (23 knots) wind speed allowed for more than 3 consecutive minutes the race shall be abandoned (this change RRS 32.1).

9 THE COURSES

9.1 The diagrams bellow show the courses, including the approximate angles between legs, the order in which marks are to be passed. All course marks (except gates) shall be left to port.

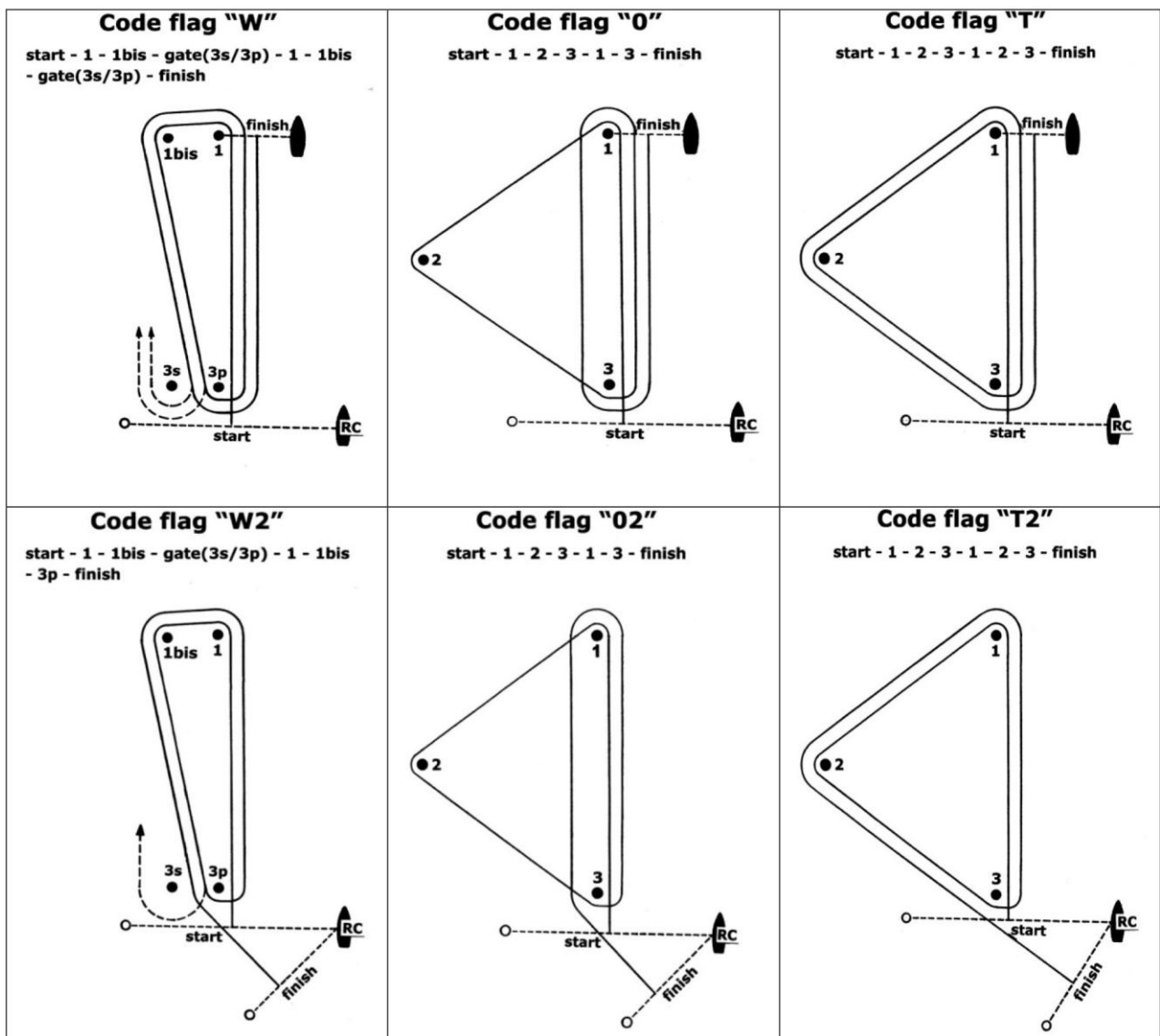

- 9.2 The course signal (code flag "W", "T", "O", "W2", "T2" or "O2") shall be hoisted one minute before the warning signal and accompanied by one sound signal. It shall remain displayed for ten minutes after the start.
- 9.3 No later than the warning signal, the Race Committee signal boat will display the approximate compass bearing of the first leg.
- 9.4 If during a race the wind and/or wave action changes to the point where the selected course would be inadvisable (See Course Selection Diagram), the Race Committee shall change the course at any mark. A change of the type of course during the race shall be signalled displaying the new appropriate flag and accompanied by repetitive sounds before the leading boat has passed or rounded the mark.
- 9.5 The number of legs in a race may be reduced (RRS code flag S) but at least 2 (two) windward legs of the race shall be completed. This change RRS 32.2.
- 9.6 A sustained wind variation of 20 degrees or more from the posted bearing during the first leg of a race shall result in the race to be abandoned and re-sailed, or abandoned. This change RRS 32.1.
- 9.7 A sustained wind variation of 40 degrees or more of the posted bearing during the first lap shall result in the race being abandoned and re-sailed, or abandoned. For the purpose of this rule a lap means the rounding of mark 3 (or passing the gate 3s/3p) for the first time. (This change RRS 32.1.)
- 10 MARKS
- 10.1 Marks 1, 1bs, 2, 3, 3s and 3p will be cylindrical white buoys.
- 10.2 New marks, as provided in instruction 13.1, will be cylindrical orange buoys with a black band.
- 10.3 The starting mark will be cylindrical orange buoy and the RC vessel.
- 10.4 The finishing mark will be cylindrical orange buoy and the RC vessel.
- 10.5 A race committee boat signalling a change of a leg of the course is a mark as provided in instruction 13.2.
- 11 THE START
- 11.1 Races will be started by using RRS 26.

- 11.2 The starting line will be between an orange flag or shape on the Race Committee boat at the starboard end and the course side of the port end starting mark.
- 11.3 A boat starting later than 5 minutes after her starting signal will be scored Did Not Start without a hearing. This changes rules A4 and A5.
- 11.4 RRS 30.4 ('Black Flag Rule') shall not be used.
- 11.5 The Race Committee, after the finish of a race and before the warning signal of a subsequent one, will do its best to post on the Race Committee boat a list of OCS and/or ZPF boats. The failure of posting or an incomplete or wrong list will not be grounds for redress.

12 CHANGE OF THE NEXT LEG OF THE COURSE

- 12.1 Changes to the next leg of the course shall be made using RRS 33. To change the next leg of the course, the race committee will lay a new mark (or move the finishing line) and remove the original mark as soon as practicable. When in a subsequent change a new mark is replaced, it will be replaced by an original mark.
- 12.2 Except at a gate, boats shall pass between the race committee boat signalling the change of the next leg and the nearby mark, leaving the mark to port and the race committee boat to starboard. This changes RRS 28.1.
- 12.3 After the completion of first windward leg of the race the remaining legs may be increased or decreased (RRS 33 + -) by not more than 30% of original length. This changes RRS 33).

13 THE FINISH

- 13.1 The finish line will be between an orange flag or shape on a Race Committee boat and the course side of the finishing mark.
- 13.2 The Alfa flag on the Race Committee boat at the finish means that there will be no more races for the day.

14 PENALTY SYSTEM

- 14.1 Appendix P will apply.

15 TIME LIMITS AND TARGET TIMES

- 15.1 The races will be managed to last 60-75 minutes for the first boat to finish. A different time (shorter or longer) used to complete the race will not be ground for requesting redress.
- 15.2 The time limit for the first boat to complete the first lap is 40 minutes from the start. If the first boat fails to complete the first lap within 40 minutes the Race Committee shall abandon the race. For the purpose of this Rule a lap means the rounding of Mark 3 (or passing the Gate 3s/3p) for the first time.
- 15.3 The time limit for the first boat to finish the race shall be 1 hour, 30 minutes. Any boat finishing more than 30 minutes after the first boat sails the course and finishes or failing to finish within 2 hours from the start, whichever is shorter, shall be scored Did Not Finish (DNF). This changes RRS 35, A4 and A5.

16 PROTESTS AND REQUESTS FOR REDRESS

- 16.1 Protest forms are available at the race office, located at location>. Protests and requests for redress or reopening shall be delivered there within the appropriate time limit.
- 16.2 The protest time limit is 90 minutes after the last boat has finished the last race of the day or the race committee signals no more racing today, whichever is later.
- 16.3 Notices will be posted no later than 30 minutes after the protest time limit to inform competitors of hearings in which they are parties or named as witnesses. Hearings will be held in the protest room, located at location>, beginning at the time posted.
- 16.4 Notices of protests by the race committee or protest committee will be posted to inform boats under rule 61.1(b).
- 16.5 Within the protest time limit, a list of boats that have been penalized for breaking rule 42 or rules 29 and 30 will be posted.
- 16.6 Any boat intending to file a request for redress, alleging that an action or omission on the part of Race Committee has made her finishing position or series score significantly worse, shall notify the Race Committee immediately after finishing that race. This modifies RRS 62.2. This instruction does not apply to request for redress resulting from scoring penalties applied without a hearing by the Jury or Race Committee or to request for redress with respect to alleged scoring errors.
- 16.7 Breaches of instructions 19, 20.3, 21, 22, 24 and NoR 3.4 (bow numbers) will not be grounds for a protest by a boat. This changes rule 60.1(a). Penalties for breaches of SI 24 may be less than disqualification or will result in denial of access of the coach boats, if the protest committee so decides. The penalty for breaking SI 19, 22 and NoR 3.4 (bow numbers) shall be the 5% scoring penalty for nearest race completed by the infringing boat but not worse than the number of points corresponding to DSQ. Penalties for breaking Class Rules, or SI 21, may be less than disqualification. The scoring abbreviation for a discretionary penalty imposed under this instruction will be DPI.
- 16.8 On the last scheduled day of racing a request for reopening a hearing shall be delivered
 - (a) within the protest time limit if the requesting party was informed of the decision on the previous day;
 - (b) no later than 30 minutes after the requesting party was informed of the decision on that day.This changes rule 66.
- 16.9 On the last scheduled day of racing a request for redress based on a protest committee decision shall be delivered no later than 30 minutes after the decision was posted. This changes rule 62.2.

- 16.10 An International Jury is constituted and is approved by SCIRA and shall have authority per RRS Appendix N. Their decision shall be final as provided in rule 70.5. Per rule N2.2, SCIRA reserves for itself the right and responsibility to decide issues of eligibility, measurement and equipment. SCIRA may refer any issue to the International Jury for advice.
- 16.11 The use of team racing tactics shall not be tolerated. If the Race Committee (acting under RRS 32.1(e)) or the Protest Committee determines that the use of team racing tactics may have significantly influenced the outcome of a race they shall order that race abandoned and, if possible, re-sailed excluding the participation of the infringing boat(s). This modifies RRS 36. If the race is not re-sailed the infringing boat(s) shall be subject to protest and disqualification.
- 16.12 For the purpose of rule 64.3(b) RRS the “authority responsible” is the Measurer of the event.
- 16.13 The Jury shall abandon the race if, during a redress hearing, they conclude that the Race Committee did not follow Sailing Instructions 8.1, 8.2, 9.5, 9.6, 9.7, and 13.3. This changes rule 64.2.

17 SCORING

17.1 Master e mixed championship races and scoring

- 17.1.1 When four (4) or fewer races are completed, a boat’s series score will be the total of her race scores. No scores will be excluded.
- 17.1.2 When five (5) or six (6) races are completed, a boat’s score will be the total of her race scores, excluding her worst score.
- 17.1.3 Master and Mixed series will be raced and scored independently. Note that according ROC 9.3, the maximum wind speed for Master will be 15knots. RC may not start or abandon their races keeping the mixed division schedule.
- 17.1.4 The RC will produce a separate scoring considering only boats eligible according NoR 3.5.

17.2 Open South American championship races and scoring

- 17.2.1 Ten (10) races are scheduled and three (3) races shall constitute a regatta.
 - 17.2.2 When five (5) or fewer races are completed, a boat’s series score will be the total of her race scores. No scores will be excluded.
 - 17.2.3 When more than five (5) and fewer than nine (9) races are completed, a boat’s series score will be the total of her race scores, excluding her worst score.
 - 17.2.4 When nine (9) races are completed, a boat’s series score will be the total of her race scores, excluding her two (2) worst scores.
- 17.3 A boat intending to retire and be scored “RET” shall report its intent in writing to the Jury

18 SAFETY REGULATIONS

- 18.1 A boat that retires from a race shall notify the race committee as soon as possible.

19 REPLACEMENT OF CREW OR EQUIPMENT

- 19.1 The same crew shall race in all races, except for reasons satisfactory to the Race Committee. Requests for a change of crew shall be submitted in writing to the Chairman. Once a crew has been excused, he/she may not return for the balance of the series.
- 19.2 The same skipper shall sail all races and can be replaced after the first race only, and then only if he/she is obviously incapacitated. If a skipper is replaced the first race shall be the race dropped, or scored DNC.
- 19.3 Substitution of damaged or lost equipment will not be allowed unless authorized by the Race Committee. Requests for substitution shall be made to the Race Committee at the first reasonable opportunity.

20 EQUIPMENT AND MEASUREMENT CHECKS

A boat or equipment may be inspected at any time for compliance with the class rules and sailing instructions. On the water, a boat can be instructed by a Race Committee equipment inspector or measurer to proceed immediately to a designated area for inspection.

21 RIGHTS TO USE NAME AND LIKENESS

By participating in this event, competitors automatically grant to the SCIRA, organizing authority and the event sponsors the right, in perpetuity, to make, use, and show, at their discretion, any photography, audio and video recording, and other reproductions of them made at the venue or on the water from the time of their arrival at the venue, until their final departure, without compensation.

22 OFFICIAL BOATS

Official boats will be marked as follows:

Race Committee: Orange Flag with letters CR on blue

International Jury: White flag with the word JURY on black

23 SUPPORT BOATS

- 23.1 At the warning signal, coaches must be positioned at least 50 meters below the starting line. After the starting signal coaches may follow the fleet, but only on the port side of the course and must stay 50 meters from any mark
- 23.2 Coaches may not communicate with competitors after the warning signal for any race until after the competitors have finished of the race.
- 23.3 Coaches shall register at the Regatta Office and all support boats shall be identified by its country letters.

24 TRASH DISPOSAL

Trash may be placed aboard support or official boats.

25 PRIZES

Prizes shall be awarded as provided by NoR.

26 DISCLAIMER OF LIABILITY

Competitors participate in the regatta entirely at their own risk. See rule 4, Decision to Race. The organizing authority will not accept any liability for material damage or personal injury or death sustained in conjunction with or prior to, during, or after the regatta.